

**ATTENTION: POUR TOUTE INTERVENTION SUR L'APPLIQUE, COUPER L'ALIMENTATION.**

**CAREFUL: FOR THIS OPERATION YOU HAVE TO CUT OFF THE POWER.**

**ACHTUNG: FÜR DIESE HAND HABUNG MÜSSEN DER STROM UNTERBROCHEN.**

**CUIDADO: PARA CUALQUIER INTERVENCION EN EL APLIQUE, CORTAR LA ALIMENTACION ELECTRICA.**

**ATTENZIONE: PER QUELUNQUE INTERVENTO SULL'APPLIQUE INTERROMPERE L'ALIMENTAZIONE ELETTRICA.**

**3170**

Luminaire Classe 3
Type de lampe: <b>LED</b> 52 ou 70W / 24V

Luminaire Classe 3
Bulb type: <b>LED</b> 52 or 70W / 24V

**3171**

Luminaire Classe 3
Type de lampe: <b>LED</b> 66 ou 88W / 24V

Luminaire Classe 3
Bulb type: <b>LED</b> 66 or 88W / 24V

**atelier sedap**

018020580-2

Tension: 230/240 --> 24 Volts.  
Fréquence: 50 Hertz.

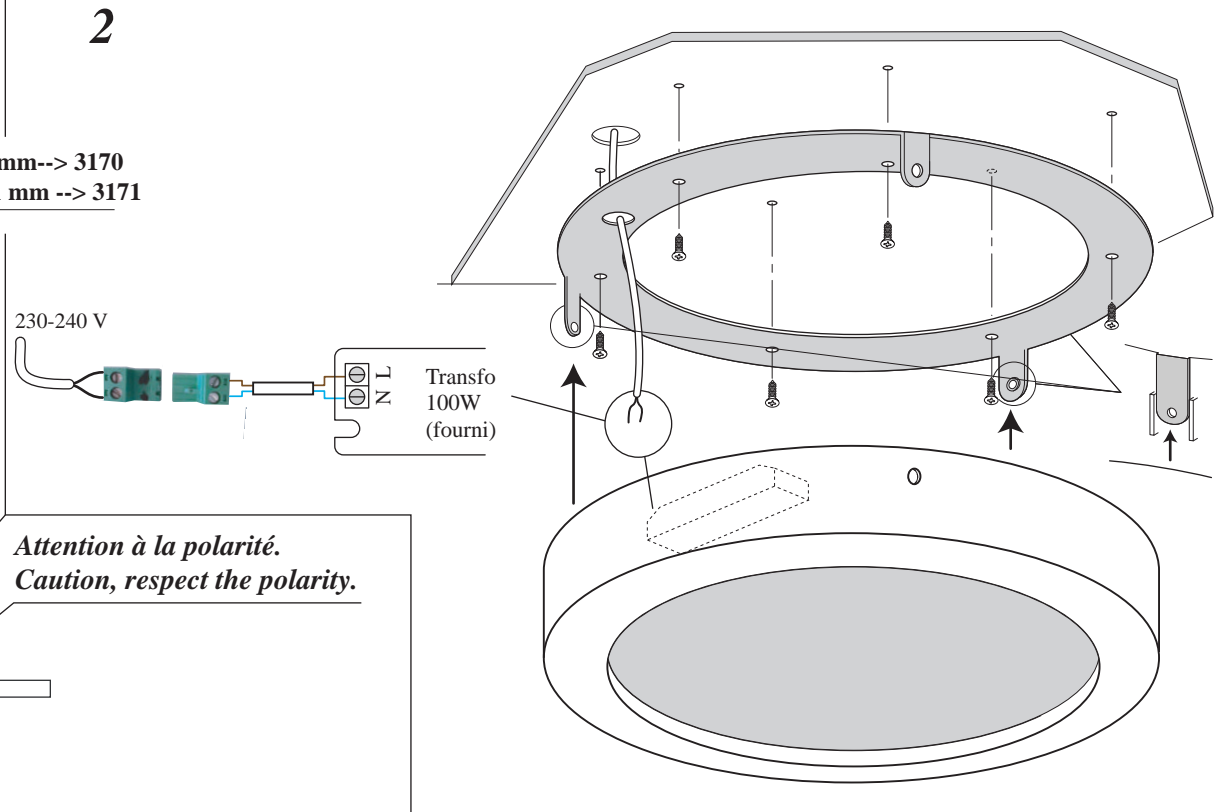
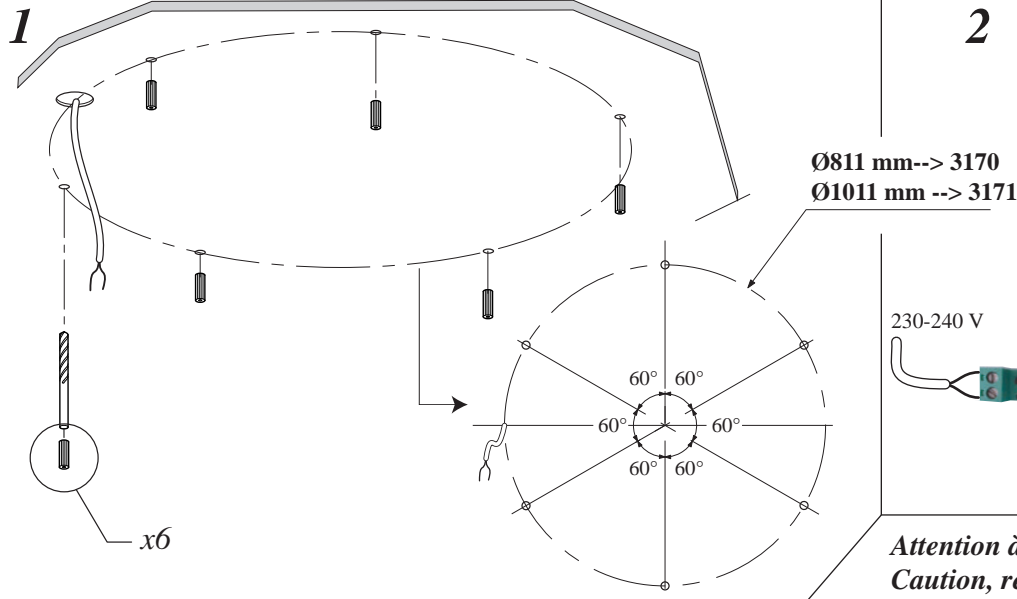

**1-10V (option)**

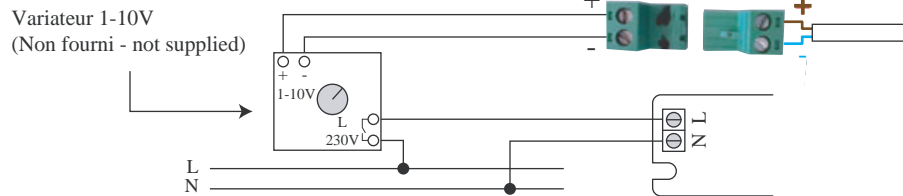

**DALI (option)**

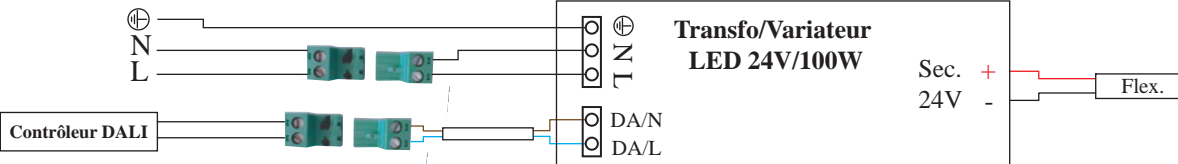

**Bouton poussoir (option)**

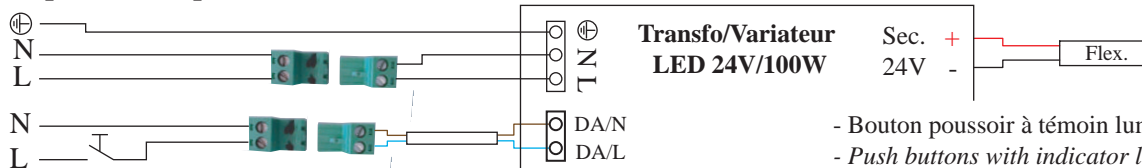

- Bouton poussoir à témoin lumineux interdit.  
- Push buttons with indicator light are prohibited.

**RVB (option) --> Cf schéma n°2.**

--> Notice télécommande consultable sur [www.sedap.com](http://www.sedap.com)

